

Operating Instructions

Single Panels

All operations should be done **slowly** with the area free of obstructions. When planning partition setup time allow a trained operator about one minute per panel.

To Extend:

1. Pull stacked panel away from stack set using slightly more force on the straight run edge.

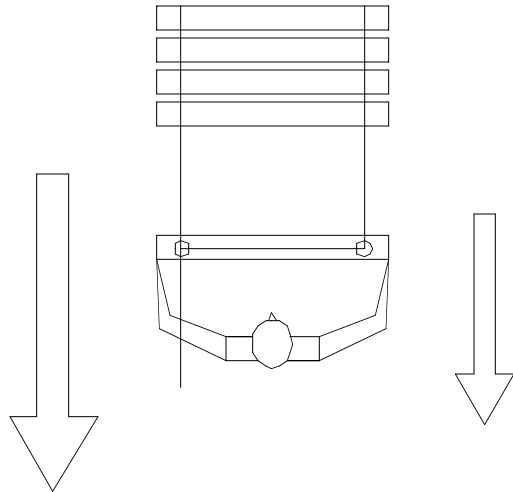

2. At the intersection push the lead edge through, grasp trail edge, push panel down the straight run.

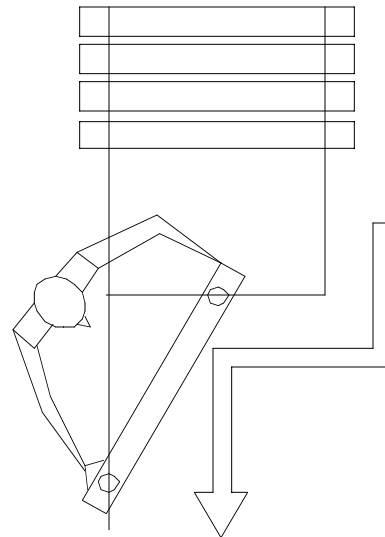

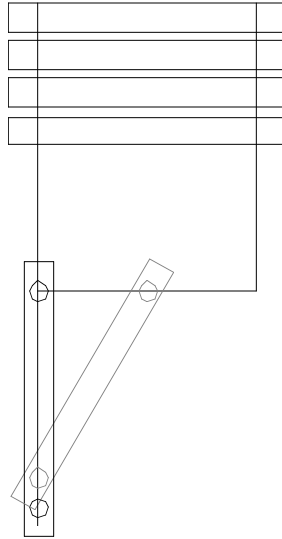

3. Slow the panel as they approach the desired location.

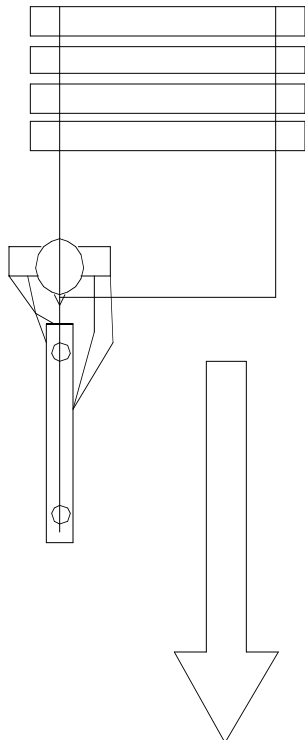

4. While putting slight forward pressure, insert operating handle (*pointing up*), rotate counter-clockwise approximately 180° until you feel a cam lock action. *Lower seals should be down.*

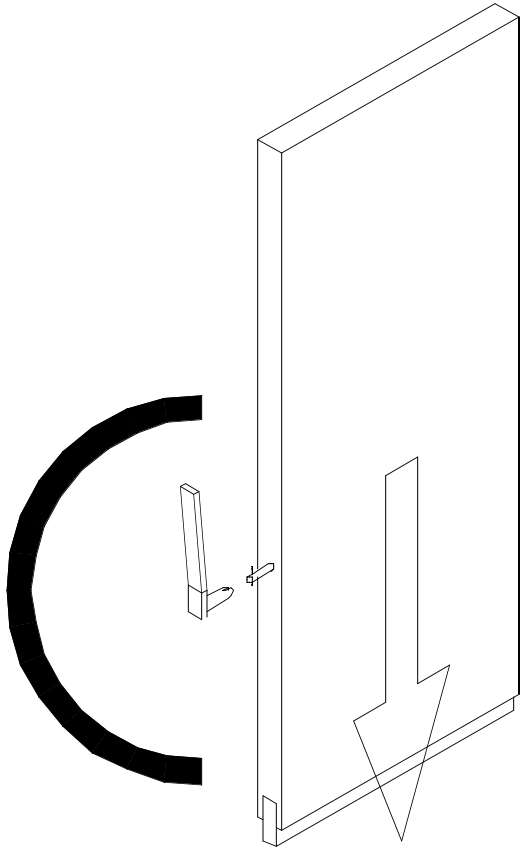

If first panel has flexible vinyl bulb it should be slightly compressed.

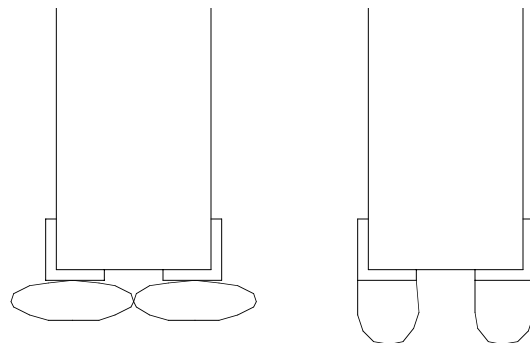

5. Return to storage stack area & repeat process. To properly seat one panel to the next allow the panel to impact the panel that was just set up *at a speed approximately _ of normal walking speed.*

6. The last panel is expanding member fabricated with an

on edge that closes against the wall.

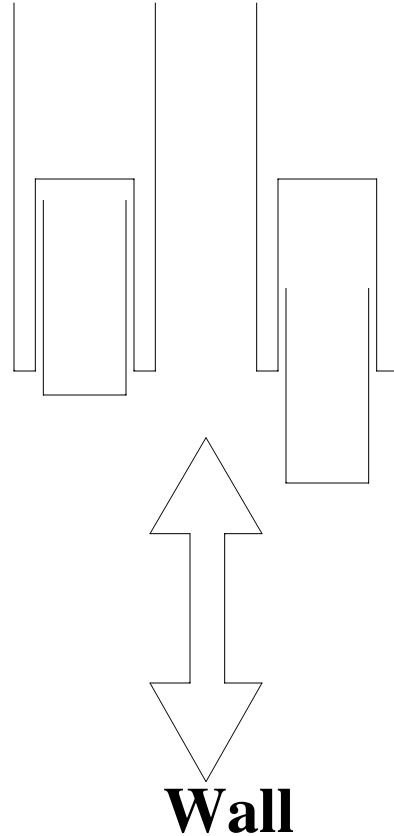
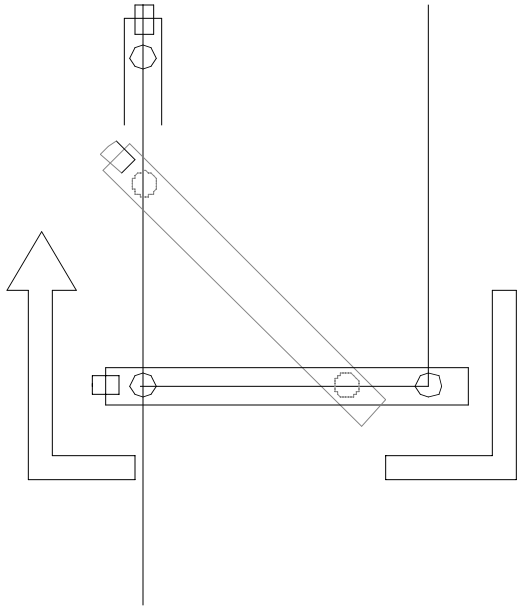

7. To help gain the needed space to insert the operating handle into the panel edge, extend the expanding closure member by inserting the handle into the cup on the face and rotate the handle. The panels should move towards bulb end.
8. Retract expanding member and **now** insert handle into panel edge with handle up, rotate 180° to lock position.
Remove handle.

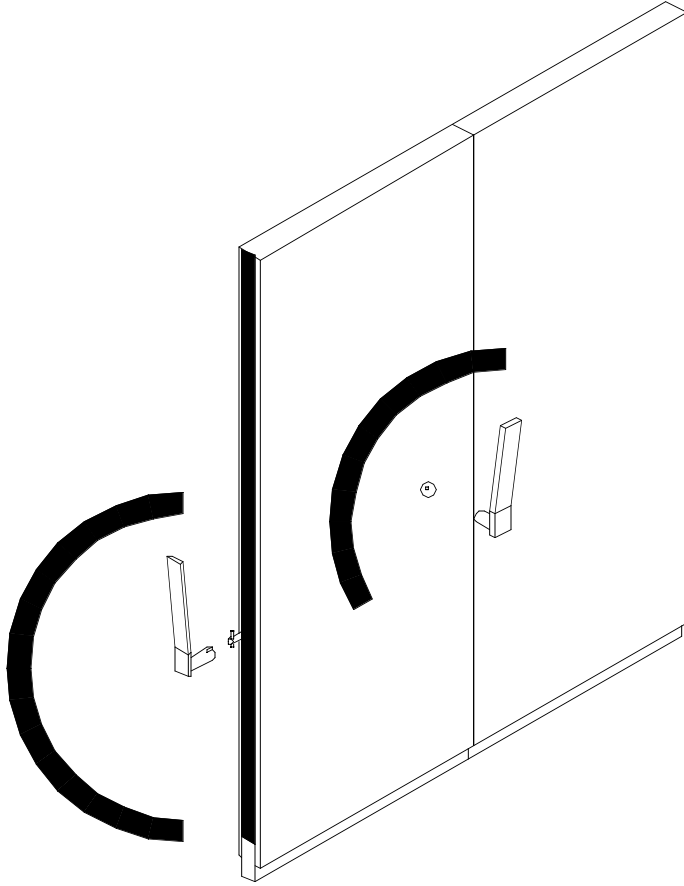

9. Put operating handle into panel face cup and rotate until there is a pronounced cam action.

To Stack:

Reverse extend process.

1. Retract the expanding member
2. Insert handle into panel edge, handle down, rotate *clockwise* approximately 180°. Bottom seal on expander panel should retract to up position. If operating is done correctly the pin in the actuating rod should be straight up and down.

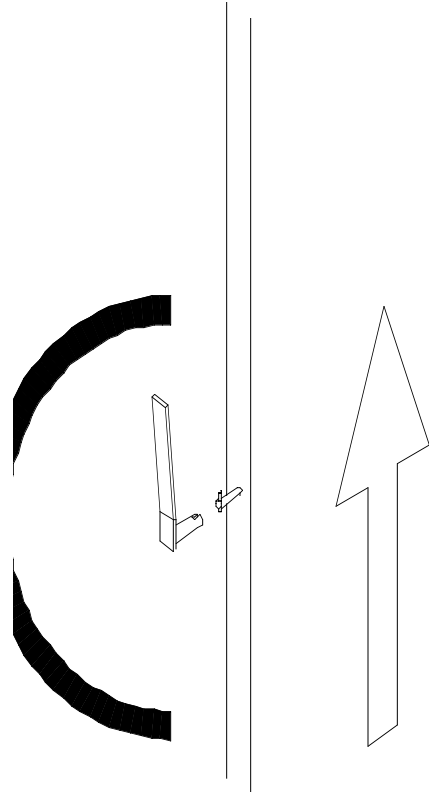

3. Slightly separate the first panel. Move to lead edge and push panel to stack position.

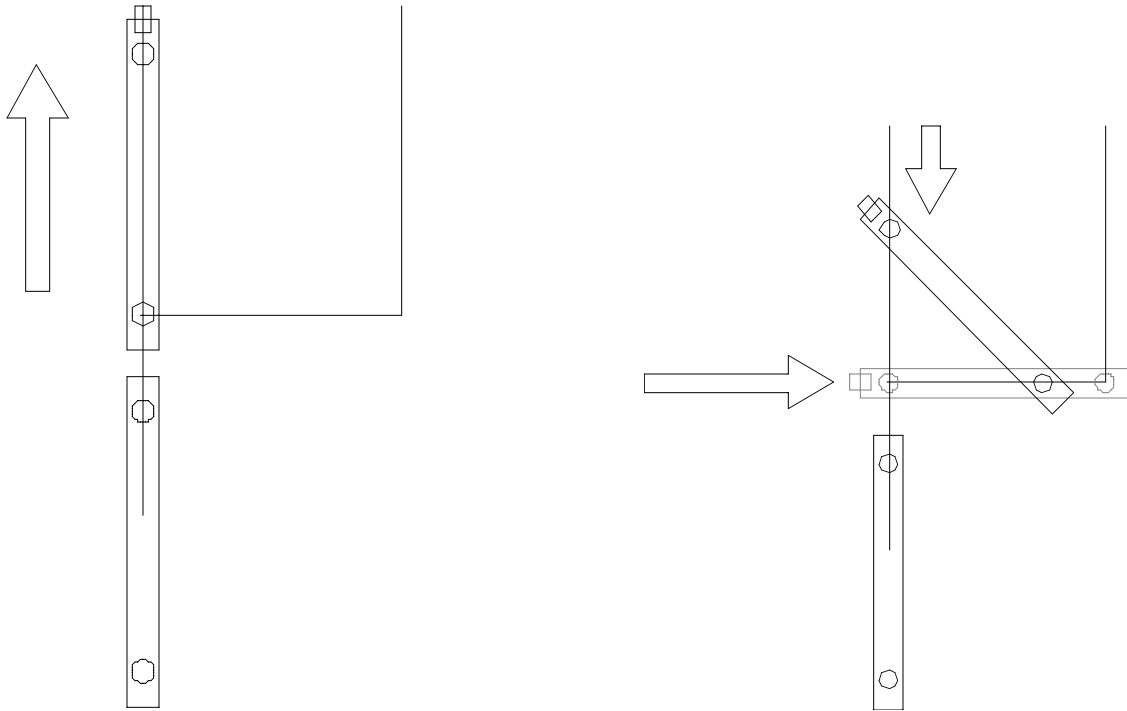

4. Push on face as near the center of the panel possible.

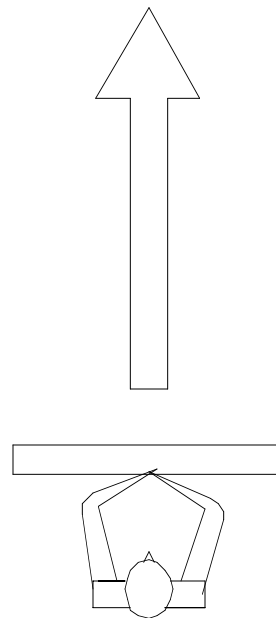

5. Slightly separate the next panel. Repeat until all panels are put into storage area.

